

Smart Label Printers®

4 Series



User Guide

Models 410, 420, 430, 440, 450

For Windows® 2000, Windows XP and Mac OS® X v10.2 or later.

SII 

Seiko Instruments USA Inc.

FCC Compliance Statement

This equipment has been tested and found to comply with the limits for a Class B digital device, pursuant to Part 15 of the FCC rules. These limits are designed to provide reasonable protection against harmful interference in a residential application. This equipment generates, uses and can radiate radio frequency energy and, if not installed and used in accordance with the instructions, may cause harmful interference to radio communications. However, there is no guarantee that interference will not occur in a particular installation. If this equipment does cause harmful interference to radio or television reception, which can be determined by turning the equipment off and on, the user is encouraged to try to correct the interference by one or more of the following measures:

- Reorient or relocate the receiving antenna.
- Increase the separation between the equipment and receiver.
- Connect the equipment into an outlet on a circuit different from that to which the receiver is connected.
- Consult the dealer or an experienced radio/TV technician for help.

Changes or modifications not expressly approved by Seiko Instruments could void the user's authority to operate the equipment.

Applicable EC Directives and Standards

Directive	Title
89/336/EEC	EC Electromagnetic Compatibility Directive
73/28/EEC	EC Low Voltage Directive
2002/96/EC	ECC Waste of Electronic Equipment (WEEE) ECC Restricting the use of Certain Hazardous Substances in Electrical and Electronic Equipment (RoHS)
Standards	Title
EMC	EN55022(1998) class B EN55024(1998), EN61000-3-2(1995), EN61000-3-3(1995)
LVD	EN60950/1992 +A1/1993, +A2/1993, +A3/1995, +A4/1997, +A11/1997

Copyright

All rights reserved. No parts of this publication may be reproduced, stored in a retrieval system, or transmitted, in any form, or by any means, electronic, mechanical, photocopying, recording, or otherwise without the prior written permission of Seiko Instruments USA Inc. No patent liability is assumed with respect to the use of information contained herein. While every precaution has been taken in the preparation of this publication, Seiko Instruments USA Inc. assumes no responsibility for errors or omissions. Nor is any liability assumed for damages resulting from the use of information contained herein. Further, this publication and features described herein are subject to change without notice. Copyright © 1989-2006 by Seiko Instruments USA Inc. All rights reserved.

Trademark Information

IBM is a registered trademark of International Business Machines Corporation. Microsoft and Windows are registered trademarks of Microsoft Corporation. SII and the SII logo are registered trademarks of Seiko Instruments Inc. Smart Label Printer is a registered trademark and SmartLabels, and Smart Label Icons are trademarks of Seiko Instruments USA Inc.

Other products mentioned in this guide are trademarks or registered trademarks of their respective companies.

Seiko Instruments USA Inc., 2990 Lomita Blvd., Torrance, California 90505 USA

Important Safety Instructions

The following symbols are used in this User Guide.



WARNING. Warning statements are used to indicate actions that may result in risk of severe personal injury or loss of life.



CAUTION. Caution statements are used to indicate actions that may result in damage to the printer or other property, or may result in risk of minor personal injury.

Warning

- 1 Use only the AC adapter provided with this printer, or an AC adapter that has been approved by Seiko Instruments for use with this printer. Use of an incorrect AC adapter may cause risk of overheating or fire.
- 2 Do not bend or place a heavy object on the power cord as it could damage the cord and result in risk of electric shock or fire. Do not use the power cord if damaged or frayed.
- 3 The thermal print head may become quite hot after printing. Be careful when changing labels and cleaning the thermal head.

Caution

- 1 Never insert objects of any kind into this printer as they may touch dangerous voltage points or short out parts, and may result in a risk of fire or electric shock. Never spill liquid of any kind on the printer.
- 2 This printer contains no user-serviceable parts. Do not attempt to service the printer yourself as this can expose you to dangerous voltage points or other risks. Repair service should be performed by a trained technician.
- 3 Do not use this printer near water or in extreme humidity.
- 4 Be sure to hold only the connector end of the power cord or interface cable when disconnecting. Repeated pulling on the cable could damage the cable.

- 5** If any of the following conditions occur, turn off the printer and unplug the power cord from the power outlet:
- The power cord is damaged or frayed.
 - Liquid has been spilled into the printer or the printer has been exposed to rain or water.
 - The printer does not recover from an error or the printer does not operate normally when the operating instructions are followed.
 - The printer exhibits a distinct change in performance, such as emitting a strange noise, odor or smoke.
- 6** Before using your SLP, please remove the clear protective tape covering on the engine cover and Roll cover.
- 7** When the SLP is unused for a period of time without a label, the platen rubber may become stuck. This condition may cause a fatal error in the printer mechanism. To avoid this, please keep a label loaded in the SLP — even when not in use.

Installation

For best performance, we recommend that you install your printer on a flat surface in a location that satisfies the following environmental conditions:

- Not subject to vibration
- Not exposed to direct sunlight
- Dust-free
- Condensation-free
- Temperatures: 15 to 35°C (59 to 95°F)
- Humidity: 30% RH to 80% RH (non-condensing)

About This Guide

As you'll soon realize, the Smart Label Printer is easy to set up and use. Chances are, once you've read what you need to know in order to get going, you won't have to use this guide except as a quick reminder or a reference.

This guide will help you set up your SLP 410, 420, 430, 440 or 450, install the software, and use your SLP.

In writing this guide we assume that you are familiar with common operations using Microsoft Windows 2000 or Windows XP on a Windows compatible PC, or Mac OS X v10.2 or later on an Apple Macintosh computer.

This guide has six sections for easy reference:

Introduction, provides some general information about the SLP 410/420/430/440/450 and the Smart Label program.

Getting Started, provides instructions for connecting the SLP 410/420/430/440/450 to your Windows-compatible PC or Mac, and loading labels into the printer. It also describes how to use on-line help.

Changing Labels and Printer Care, provides information for replacing a label roll and taking care of your SLP.

Specifications, provides SLP 410/420/430/440/450 specifications.

Commonly Asked Questions and Answers, provides a list of questions and answers that can help you resolve problems.

Technical Support and Service, provides technical support and service information.

Ordering Labels and Parts, provides information for ordering SmartLabels and replacement parts and accessories.

Contents

Introduction	1
About Your Smart Label Printer	1
Software Features	1
Getting Started	2
What You Need	2
A Word About Labels	3
Caring for Labels	3
Installing the SLP 410, 420, 430, 440 or 450	4
Unpacking the SLP	4
Installing the Software	5
Connecting the SLP to a Power Outlet	5
Connecting the SLP to your computer	6
Setting up the Printer	7
Loading a Roll of Labels	7
Testing the Printer	9
Changing Labels and Printer Care	10
Overview	10
Caring for Your Printer	10
Off Line and On Line Mode	11
Changing a Label Roll	11
Removing the Old Roll	11
Loading the New Roll	11
Adjusting the Position of Labels	12
Removing Stuck Labels	13
Specifications	14
Smart Label Printer 410/420/430/440/450 Specifications	14
Status Light Indicators	15
Commonly Asked Questions and Answers	16
Technical Support and Service	17
Ordering Labels and Parts	17
Ordering Labels	17
Ordering Parts	17

Introduction

About Your Smart Label Printer

The Smart Label Printer is the best way to instantly print one-at-a-time labels. Direct thermal printing technology does not use ink, toner or ribbon, just labels. The SLP produces fast, laser quality output on a variety of label sizes with the ability to print text, graphics, POSTNET codes and bar codes.

With the wide variety of available SmartLabels, you can use your SLP to create labels for just about anything. Here are some examples:

- Envelope labels
- File folder labels
- Name tags
- Shipping labels
- Storage container labels
- Notebook labels
- Bar code labels
- Diskette labels
- Rotary file cards
- Videocassette labels
- Binder labels
- Shelf labels

Software Features

The Smart Label program provides a rich set of features to simplify your labeling needs.

- WYSIWYG editor displays labels as they will print.
- Prints in background so you can work with other applications while labels are printing. Print labels one at a time or whole mailing lists.
- Object-oriented user interface makes it easy to include text, pictures, bar codes, etc. on your label.
- Mixed text possible within each text object—different font types, sizes and styles (bold/italic/underline) can be included on a single line.
- Shrink-to-fit and word wrap ensure that addresses and other text fit on the label.
- Built-in database to save labels and formats in user-definable database categories.
- Find feature makes it easy to locate saved labels by label name, database field or words within the label.
- Contact-based records updated automatically from label addresses.

Getting Started

What You Need

In order to use your SLP and software, you need to have the following:

PC Users:

- Windows 2000 or Windows XP
- IBM PC or compatible using 233MHz or higher Pentium-compatible CPU
- Minimum 64MB RAM, 128MB recommended
- 16MB hard disk space
- RS232C serial port or USB port
- CD-ROM or DVD drive

Mac Users:

- Mac OS X v10.2 or later
- PowerPC® G3/G4/G5 or Intel Core processor
- Minimum 128MB RAM, 256MB recommended
- 30MB hard disk space
- USB port
- CD-ROM or DVD drive

A Word About Labels

For best results we recommend the use of Seiko Instruments SmartLabels. Other brands may not be engineered to provide optimum, trouble-free results with your SLP; they may not work with your printer or they may damage it and void your warranty.

SmartLabels are available in a wide variety of sizes and colors to properly label almost anything.

The SmartLabels have a sensor mark on the backing of each label that the SLP 410/420/430/440/450 uses for top of label alignment. Check to be sure the labels have this mark before loading them into the SLP.

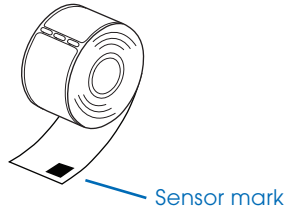

Note... Older SmartLabels did not have this sensor mark. Be sure that the SLP 410, 420, 430, 440 and 450 are listed as supported printers on the SmartLabels package.

Caring for Labels

The labels are sensitive to heat, moisture, and light. With this in mind:

- Store labels in a cool, dry place.
- Do not scratch or rub labels with a hard object.
- Keep organic solvents away from labels.

Installing the SLP 410, 420, 430, 440 or 450

Here, you'll find out how to unpack and set up your new SLP. As part of the setup process, you'll load a roll of standard address labels and run a quick test.

Unpacking the SLP

Carefully remove the printer and its components from the box. It's a good idea to save the box and packing materials in case you need to store or ship the printer. Make sure you have all of the following items.

- A Smart Label Printer 410, 420, 430, 440 or 450
- Smart Label software with User Guide
- Serial cable
- USB cable
- AC adapter
- Power cord (SLP 430 or 450 only)
- Starter roll of SmartLabels
- Quick Start Guide

Smart Label Printer
410, 420, 430,
440 or 450



SmartLabels

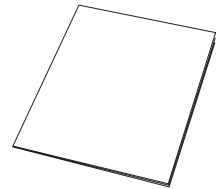
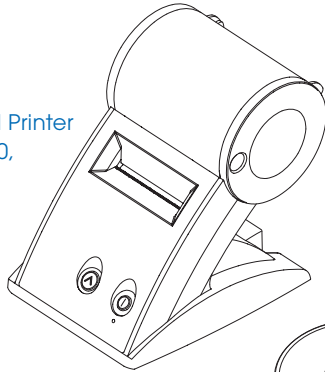

Quick Start

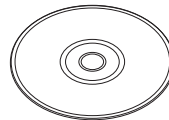

Smart Label Software

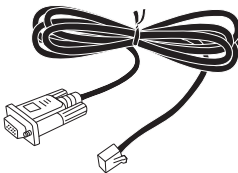

Serial Cable

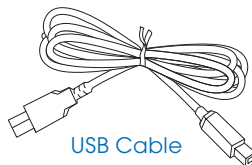

USB Cable

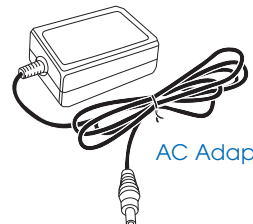

AC Adapter

Installing the Software

Installing the Smart Label Program for MacOS X

- 1 Insert the Smart Label CD. If the installer does not appear automatically, double-click the CD on your desktop or in the left pane of a new Finder window.
- 2 Double-click the file *SIISmartLabelPrinter.mpkg*. The installer will appear. Follow the on-screen instructions.
- 3 For Mac OS X 10.2: After installation is complete, open *Print Centre* and select your SLP printer. Mac OS X 10.3 or 10.4 will automatically set up your printer.

Installing the Smart label Program for Windows

- 1 Insert the Smart Label CD. The installation wizard starts automatically on most systems. If the introductory screen doesn't appear after a few seconds, do the following:
- 2 Click the Windows *Start* button then point to *Settings* and choose *Control Panel*.
- 3 Double-click *Add/Remove Programs* then click the *Install* button. Follow the install wizard to assist with installation.

Please note: If your printer is not recognized or all label templates do not appear, you will need to set-up your printer within the SLP printer software. Please see *Setting up the Printer* on page 7.

Connecting the SLP to a Power Outlet

Now you're ready to connect the SLP to a power outlet:

- 1 Plug the AC adapter cable into the jack at the rear of the SLP and the other end into a power outlet.
- 2 Turn the SLP on by pressing the  power button.

When you turn the printer on, the status light flashes green. This is just to let you know there are no labels in the printer.

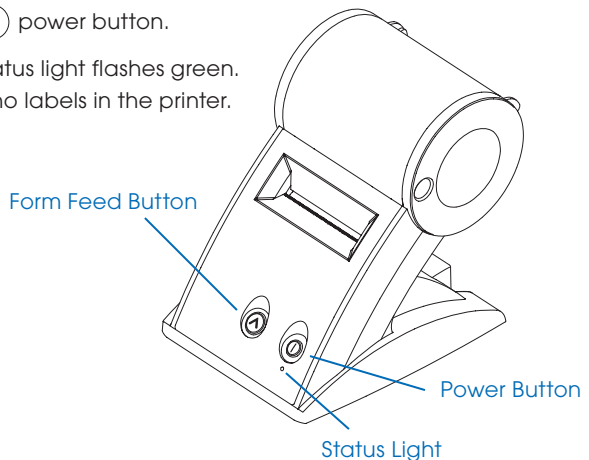

Connecting the SLP to your computer

Use the USB or serial cable provided with the SLP 410/420/430/440/450 to connect the SLP to your computer.



CAUTION: Connecting or disconnecting the interface cable while the printer is turned on may damage the printer.

Follow these steps:

- 1 Make sure that the SLP is turned off. If the status light is on, hold the power button until it turns off.
 - 2 Connect the printer to your PC or Mac.
 - The SLP can be connected to either the Serial or USB port on your PC. On a Mac use the USB port.
 - Insert either the USB or Serial cable into the appropriate port on your computer. *Do not use both cables.*
 - If all USB ports are in use, you may need to purchase a USB hub.
- Note...** Serial ports are also called COM ports — COM1, COM2, COM3, etc. If your COM ports are all in use, purchase either another serial port or an “A-B” switch box to connect the SLP and another device to the same port.
- Connect the other end of the cable into the appropriate port on the back of the SLP.

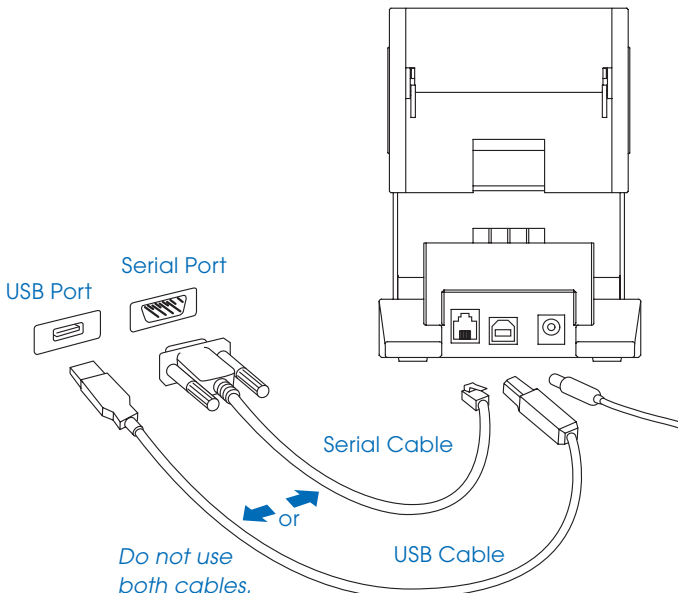

Setting up the Printer

If the printer is not recognized using the installation wizard, you will need to set up your printer manually. To do so, follow these steps:

Prepare the roll of labels

- 1 Open the Smart Label printer software
- 2 Under the *Label* pull-down menu, select *Printer Set-up*
- 3 Select *Add a printer*
- 4 Select how your printer is connected and click *Done*.

Loading a Roll of Labels

Prepare the roll of labels

- 1 Remove the sticker from the beginning of the roll of labels.

Note: Make sure there is a black sensor mark on the label backing as shown on page 3.

- 2 If needed, cut between the labels to create a "leader."

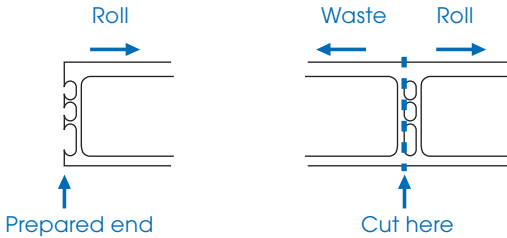

If the end of the roll is not prepared as shown above, cut between the labels leaving as much backing as possible on the end of the roll to act as a leader.

Load the roll of labels

- 1 Make sure the power cord is connected and the printer is turned on. The green status light should be flashing.
- 2 Lift the base of the label cover and rotate it open.

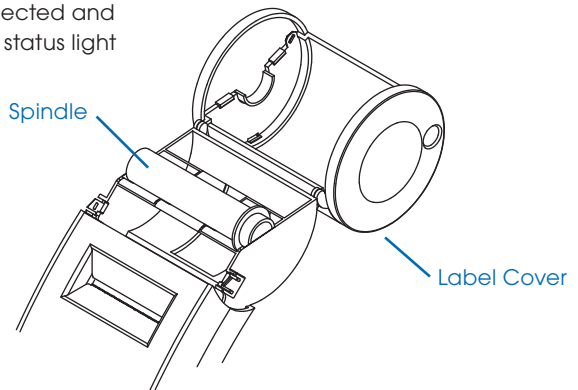

- 3 Remove the spindle from the SLP and insert the label roll on the spindle.
- 4 Insert the labels and spindle into the SLP. If using an SLP 420, 430, 440 or 450, adjust the guides to fit the labels as shown below.

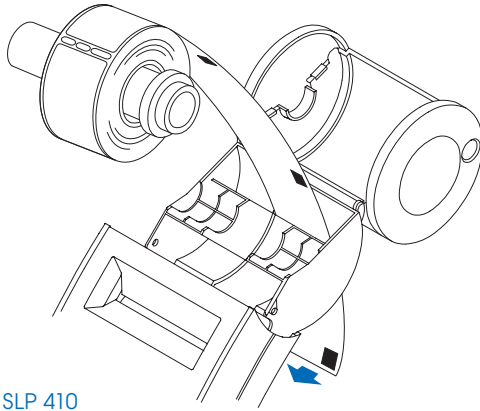

SLP 410

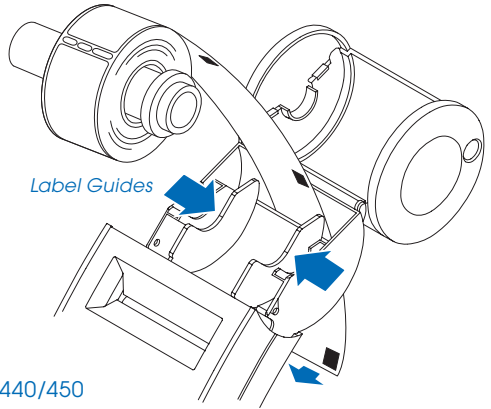

SLP 420/430/440/450

- 5 Insert the free end of the label roll, label side down, into the slot on the back of the printer. Push the label stock into the slot until you feel a slight resistance. Continue pushing gently. The SLP automatically feeds the labels through and aligns the end in the exit slot.

If the label end doesn't appear through the slot:

Press and release the  form feed button to advance the labels.

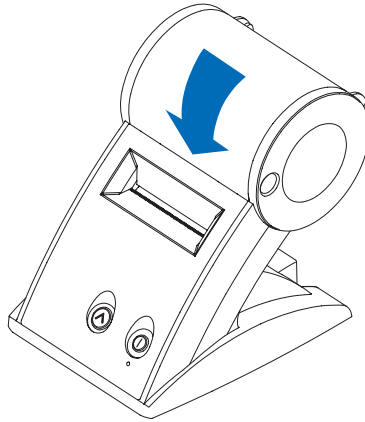

6 Close the label cover.



Testing the Printer











A quick test lets you know your printer is operating properly and that the labels are loaded correctly.

Testing the SLP 410, 420 or 430

- 1 Press and hold the  power button for 2 seconds to turn the printer off.
- 2 Press and hold the  form feed button while you press and release the  button.

If the test is successful, the SLP 410/420/430 will print a test label.

Testing the SLP 440 or 450

- 1 Press and hold the  power button for 2 seconds to turn the printer off.
- 2 Press and hold the  form feed button until the LED begins to flash green. Do not release.
- 3 To print the SII graphic logo:
 - While holding the  button, press the  power button 1x and release both buttons.
- 4 To print the SII sample address label:
 - While holding the  button, press the  power button 2x and release both buttons.
- 5 To print the density test:
 - While holding the  button, press the  power button 3x and release both buttons.
- 6 To print the serial number and firmware:
 - While holding the  button, press the  power button 4x and release both buttons.

Changing Labels and Printer Care

Overview

The SLP 410/420/430/440/450 uses advanced thermal print technology to provide crisp, high-contrast printing. There are no ribbons or cartridges to replace.

An important consideration... For best results we recommend the use of Seiko Instruments SmartLabels. Other brands may not be engineered to provide optimum, trouble-free results with your SLP; they may not work with your printer or they may damage it and void your warranty.

Caring for Your Printer

Your SLP 410/420/430/440/450 is a high-precision device that's designed for trouble-free operation. Just follow these few precautions:

- *Important...* The SLP 410/420/430/440/450 is designed for use only with Seiko Instruments SmartLabels. Use of improper labels may damage the printer.
- Don't operate the printer in a dusty environment.
- Keep the printer out of direct sunlight.
- If you are printing more than one label at a time, guide the labels over the front of the label cover as they exit, making sure that they don't curl under or over the cover and loop through and into the feed slot.

Off Line and On Line Mode

Pressing and releasing the  power button toggles the printer between off line and on line mode. An amber status light indicates that the printer is off line. There is no communication with the computer when the printer is off line.

This feature is a handy way to stop printing so you don't waste labels while you delete labels from the print queue.

Changing a Label Roll

This procedure describes how to remove and replace label rolls.

- You can load a different type of label at any time — you don't have to wait until all of the labels have been used.
- When you run out of labels, the green status light on the front of the SLP flashes. If printing is in process, a message appears telling you that the printer is out of labels.

Removing the Old Roll



CAUTION: DO NOT pull on the labels to remove them from the printer. This may cause labels to get stuck inside the printer.

- 1** Tear off any printed labels. If labels aren't torn off, they may get jammed when you perform step 2.
- 2** Press and hold the  form feed button. The labels will reverse out of the SLP. If this does not work, see "Adjusting your Label Position" on Page 12 to release the platen to remove the labels.

Loading the New Roll

Prepare and load the new label roll as described in "Loading a Roll of Labels" on page 7.

Adjusting the Position of Labels

If you find the labels are advancing at an angle, it's easy to realign them. Follow these steps:

- 1 Swivel the label cover open and remove the print engine cover by pulling forward on the edges at the top of the cover.
- 2 Release the pressure on the label stock by moving the platen release lever forward.

Remove the print engine cover

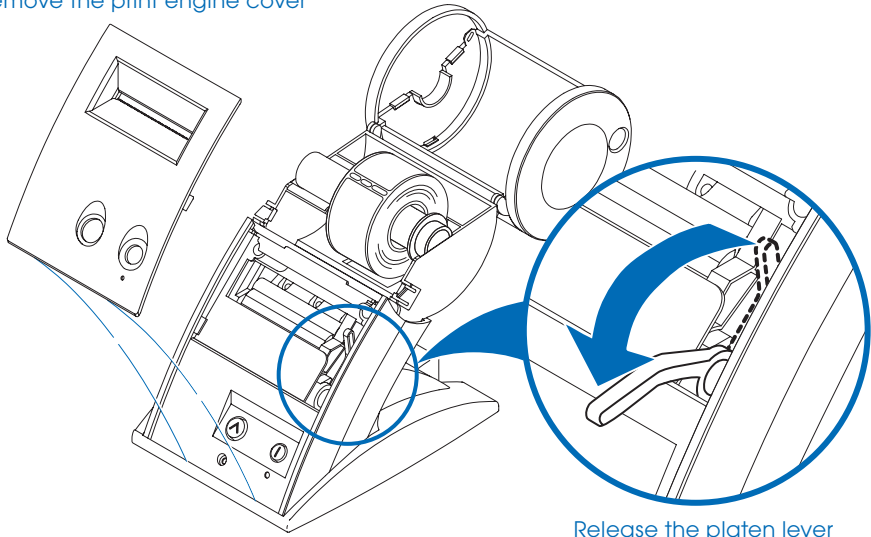

- 3 Realign the label stock so it is straight.
- 4 Return the platen release lever to the locked position.
- 5 Make sure the labels feed through the slot.
- 6 Replace the print engine cover, starting at the bottom, on the SLP and push the top edge forward until the cover snaps into place.

Removing Stuck Labels

If a label becomes stuck in your SLP, remove it as follows:

- 1** With a pair of scissors, cut the label stock between the label roll and the label slot at the back of the printer.
- 2** Swivel the label cover open and remove the print engine cover by pulling forward on the edges at the top of the cover.
- 3** Release the pressure on the label stock by moving the platen release lever forward.
- 4** Remove the stuck label.
- 5** If the label — or pieces of the label — stick to the platen, use a small amount of isopropyl rubbing alcohol on a cotton swab to dissolve the adhesive on the back of the label.



CAUTION: DO NOT touch the print engine. It may be hot.

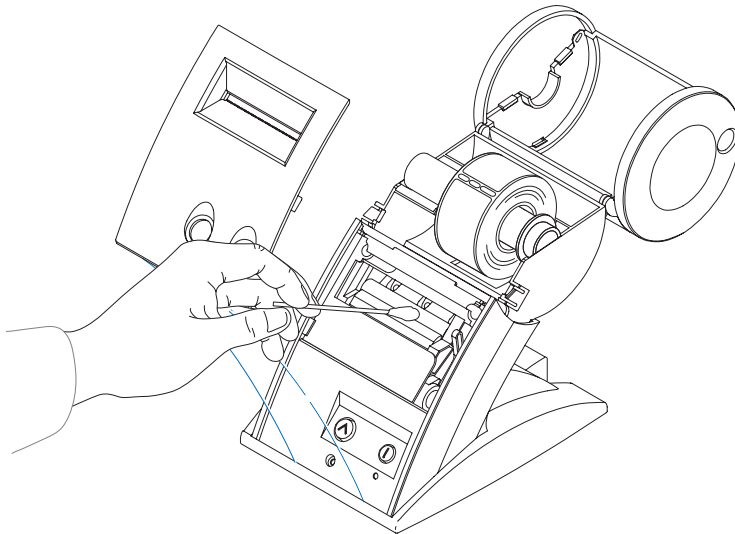

- 6** Once you have removed any remaining pieces of label, return the platen release lever to the locked position.
- 7** Replace the print engine cover, starting at the bottom, on the SLP and push the top edge forward until the cover snaps into place.

Specifications

Smart Label Printer 410/420/430/440/450

The SLP is a compact printing device ideally suited for label printing applications. There are no built-in fonts and any text must be converted to a bitmap image by a host computer or device for printing on the SLP.

Developer information can be found on our website at www.siibusinessproducts.com

Printer

<i>Technology</i>	Direct thermal	
<i>Resolution</i>	Model 410/420/430	203 dpi (8 dots/mm)
	Model 440/450	300 dpi (11.81 dots/mm)
<i>Max. Paper Width</i>	Model 410	31mm (1.22 in.)
	Model 420/430/440/450	58mm (2.28 in.)
<i>Max. Printable Width</i>	Model 410	24mm (0.94 in.)
	Model 420/430/440/450	48mm (1.89 in.)
<i>Print Speed</i>	Model 410	4-5 seconds*
	Model 420	3-4 seconds*
	Model 430	2-3 seconds*
	Model 440	2-3 seconds*
	Model 450	1-2 seconds*

*average speed, standard address label

Interface USB and RS-232

Power

Input

Model 410/420/440 AC adapter:

PW-0006-WH-U1 AC 100-120V, 50/60 Hz
(US version)

PW-0006-WH-E1 AC 200-240V, 50/60 Hz
(EU version)

PW-0006-WH-K1 AC 200-240V, 50/60 Hz
(UK version)

PW-0006-WH-A1 AC 200-240V, 50/60 Hz
(AU version)

Model 430/450 AC adapter:

PW-0012-WH-W1
(universal) AC 100-240V, 50/60 Hz

CB-WH-US2 AC Cord for USA

CB-WH-EU2 AC Cord for EU

CB-WH-UK2 AC Cord for UK

CB-WH-AU2 AC Cord for Australia

<i>Output</i>	Model 410/420/440: DC6V 1.5A (2.0A max.) Model 430/450 DC12V, 3.0A (5.0A max.)
<i>Dimensions</i>	117mm (W) x 160.9mm (D) x 157.9mm (H) 4.61 in. (W) x 6.34 in. (D) x 6.22 in. (H)
<i>Weight</i>	All models 515 grams (1.14 lbs.)
<i>Life Time</i>	Model 410/420: Approx. 2 million characters (24 H x 12 W dots) Model 430: Approx. 5 million characters (24 H x 12 W dots) Model 440/450: Approx. 2.5 million characters (24 H x 12 W dots)

Environment

<i>Temperature</i>	Operating:	15°C to 35°C (59°F to 95°F)
	Storage:	-20°C to 60°C (-4°F to 140°F)
<i>Humidity</i>	Operating:	30% RH to 80% RH (non-condensing)
	Storage:	30% RH to 90% RH (non-condensing)

Status Light Indicators

LED Indicator	State
Off	Power off/Stand-by
Steady Green	On-line
Steady Amber	Off-line
Blinking Green 1*	No labels
Blinking Green 2*	Print head up
Blinking Amber 1*	Label jam
Blinking Amber 2*	Buffer overflow
Blinking Red 1*	Temperature error
Blinking Red 2*	Voltage error
Blinking Red 3*	Print head error
Blinking Red 4* (SLP 440/450)	Print head error

* The number refers to the number of blinks.

Frequently Asked Questions and Answers

Q *Will my labels fade over time?*

A Labels are made of thermal paper. Heat applied to the paper causes a chemical reaction to generate black dots at the points where heat was applied. This technique avoids using messy inks and ribbons. Because the paper is heat-sensitive, it is possible for a label to darken if exposed to high heat or very bright light for an extended period of time. It is also possible for certain plasticizers in some plastic binders to cause a chemical reaction which results in the image fading over time. Placing another adhesive (perhaps another label) between the vinyl surface and the label may help minimize this type of fading.

In general, labels will last for years if they aren't subjected to the above conditions. The label material is much more stable than fax paper due to the special formulation and coatings used by Seiko Instruments.

Q *How many labels can I save?*

A The number of labels you can save is limited only by the amount of disk space in your computer.

Q *There are no available serial or USB ports on the back of my computer. What do I do?*

A You may wish to add another port to your system. Alternatively you may use a switch box to share a serial port or a USB hub to extend the number of USB devices that can be connected.

Technical Support and Service

Please refer to the “Troubleshooting” topic in on-line Help for information on how to determine if your SLP needs service and how to contact Seiko Instruments for Technical Support and repairs.

You can contact Technical Support on our website under the Support section at:
www.siibusinessproducts.com

Ordering Labels and Parts

Ordering Labels

For best results we recommend the use of Seiko Instruments SmartLabels. Other brands may not be engineered to provide optimum, trouble-free results with your SLP; they may not work with your printer or they may damage it and void your warranty.

For information on ordering labels, please choose the How to Order Labels command on the Help menu or refer to the “Ordering Labels” topic in on-line Help.

You can order labels directly from Seiko Instruments on our website at the following address: **www.siibusinessproducts.com**

Ordering Parts

For information on ordering replacement parts and accessories, please refer to your SLP model in the “Troubleshooting” topic in on-line Help.

You can order parts directly from Seiko Instruments on our website at the following address:
www.siibusinessproducts.com



Seiko Instruments USA Inc.